

Outdoor use.

**Attention. Réservé à un usage familial.**

*Warning. Only for domestic use.*

**La structure d'activité doit être mise en place sur une surface nivelée en prévoyant une zone de 2 m entre celui-ci et toute autre structure ou obstacle tel qu'une barrière, un garage, une maison, des branches d'arbre, des fils à linge ou des câbles électriques.**

*Activity structure should be placed on a level surface at least 2 m from any structure or obstruction as a fence, garage, house, overhanging branches, laundry lines or electrical wires.*

**Installer les fixations au sol en respectant les instructions (selon les caractéristiques du sol) afin d'écartier les risques de renversement ou de soulèvement des éléments de la structure pouvant survenir dans les conditions d'utilisation normale ou de mauvaise utilisation prévisible.**

*Install fixations on the ground by respecting the instructions (taking account ground characteristics) to prevent overturning or lifting of the support members when they are used as intended or in a foreseeable way.*

**Les fixations au sol doivent être placées au niveau du sol ou sous le sol afin d'écartier tout risque de trébuchement.**

*The anchors shall be placed level with or under the ground in order to reduce tipping hazards.*

**Les jouets d'activité ne doivent pas être installés sur du béton, de l'asphalte, ou tout autre revêtement en dur.**

*Activity toys shall not be installed over concrete, asphalt or any other hard surface.*

**Conserver les instructions de montage et d'installation pour référence ultérieure.**

*Keep the assembly and installation instructions for further reference.*

**Toute modification apportée au jouet d'origine (par exemple l'ajout d'un accessoire) doit être effectuée conformément aux instructions fournies par le fabricant.**

*Any modifications made by the consumer to the original activity toy (for example the adding of an accessory) shall be carried out according to the instructions of the manufacturer.*

**Il est nécessaire d'effectuer des vérifications et des opérations de maintenance sur les parties principales (barres transversales, moyens de suspension, fixations etc.) à intervalles réguliers, à défaut de procéder à ces vérifications, le jouet pourrait se renverser ou constituer un danger.**

*It is necessary to carry out checks and maintenance of the main parts (crossbeams, suspensions, anchors etc.) at regular intervals, if these checks are not carried out the activity toy could overturn or otherwise become a hazard.*

**Vérifier tous les écrous et boulons et les resserrer si nécessaire.**

*Check all nuts and bolts for tightness and tighten when required.*

**Graisser toutes les parties mobiles métalliques.**

*Oil all metallic moving parts.*

**Vérifier tous les caches des boulons ou des bords coupants et les remplacer si nécessaire.**

*Check all coverings for bolts and sharp edges and replace when required.*

**Vérifier les sièges balançoires, les chaînes, les cordes et autres dispositifs de fixation à la recherche de signes de dégradation.**

*Check swing seats, chains, ropes and other means of attachments for evidence of deterioration.*

**Remplacer les éléments défectueux conformément aux instructions du fabricant.**

*Replace defective parts in accordance with the manufacturer's instructions.*

Avant d'autoriser les enfants à entrer à l'air de jeu, vérifiez que toutes les vis sont bien serrées. Jeu sous la supervision des parents.

Before letting children into the playground, check that all screws are properly tightened. Use by children, under parental supervision.

NOTICE DE MONTAGE / ASSEMBLY INSTRUCTION

# Aire de jeux / Playground Kubúś

PZ0022B

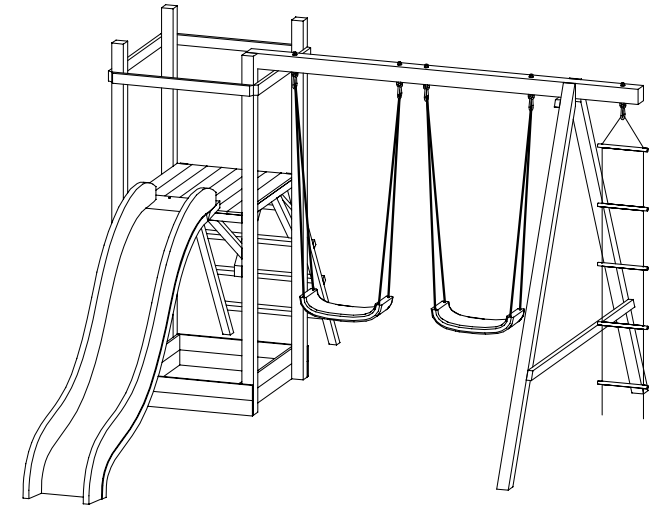

**LE BOIS EST UNE MATIÈRE NATURELLE.  
TOUTES LES FISSURES APPARENTES SONT D'ORIGINES ET  
NE PEUVENT ÊTRE CONSIDÉRÉES COMME UNE MALFAÇON.**

**LA MADERA ES UN MATERIAL NATURAL.  
TODAS LAS FISURAS SON DE ORIGEN Y NO PUEDEN SER  
CONSIDERADAS COMO UN DEFECTO**



• Easy assembly  
• Montage facile  
• Leichte Montage  
• Montaje fácil  
• Montagem fácil

**Attention. Ne convient pas aux enfants de moins de 36 mois (ou 3 ans). Danger de chute.**

*Warning. Not suitable for children under 36 months (or 3 years). Falling hazard.*

**Le produit doit être assemblé par un adulte**

*Toy intended to be assembled by an adult*

**Age minimum :**

**3 ANS**

*Minimum age :*

**3 YEARS**

**Age maximum :**

**12 ANS**

*Maximum age :*

**12 YEARS**

**Masse maximale :**







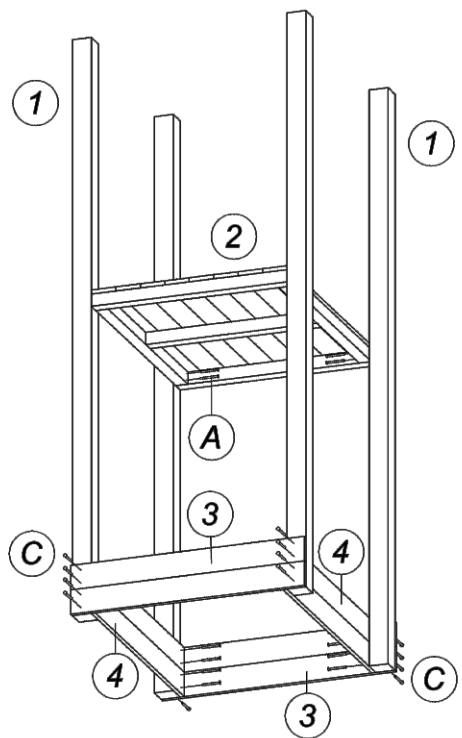

**100 kg**

*Maximum weight :*

**100 kg**









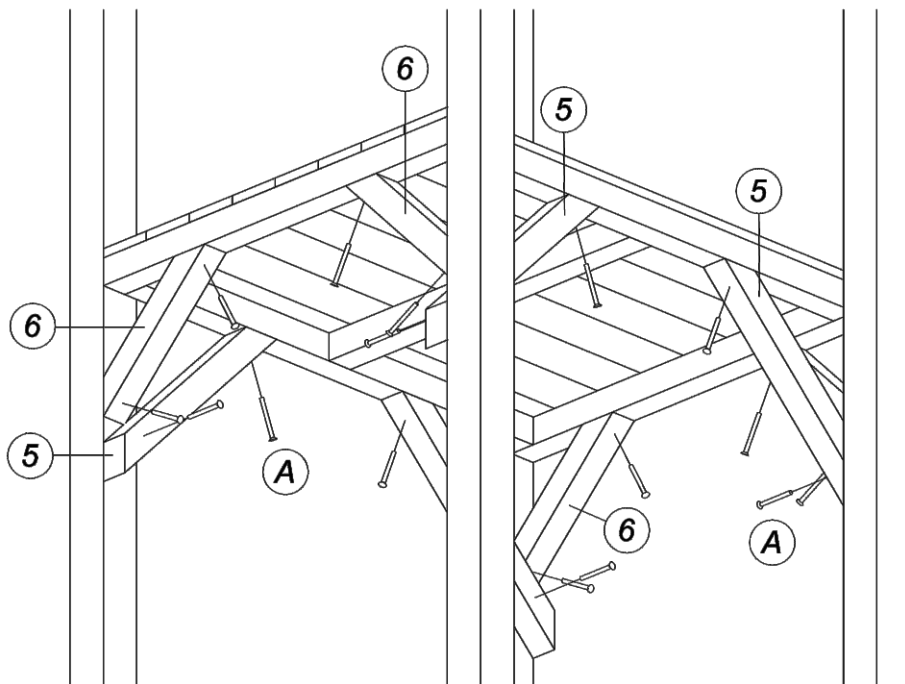

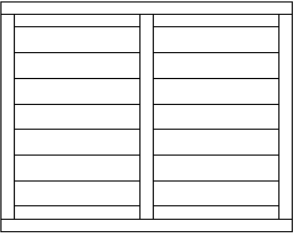
1

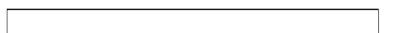

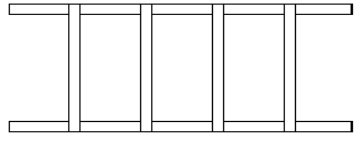
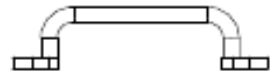
17		Cornière en acier / Metal angle		1
18		Balançoire / Swing		2
19		Échelle de corde / Rope ladder		1
A		Boulon à bois / Wood screw	80x4	32
B		Boulon à bois / Wood screw	50x3,5	28
C		Boulon à bois / Wood screw	35x3	32
D		Boulon à bois / Wood screw	35x5	2
E		Boulon de carriage + rondelle + écrou / Bolt + washer + nut	M8	1
F		Tige fileté M8x200 + 2 rondelles + 2 écrous + 2 bouchons en plastique / Threaded rod + washers + nuts + plastic covers		1

2

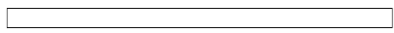

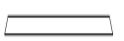
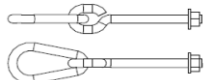
N°		Nom / Name	Dimensions	Quantité
1		Poteau / Tower pillar	70x70x2120	4
2		Plate-forme / Floor	720x900	1
3		Planche du socle / Plinth board	90x15x860	4
4		Planche du socle / Plinth board	90x15x900	4
5		Poutre oblique / Strut	45x45x450	4
6		Poutre oblique / Strut	45x45x300	4
7		Échelle / Ladder	1410x690	1
8		Prise en plastique / Plastic handle		2
9		Garde-corps avant et arrière / Front and rear railing	60x25x860	2
10		Garde-corps latéral / Side railing	60x25x900	2
11		Toboggan / Slide		1
12		Poutre du balançoire / Swing beam	90x90x2380	1
13		Pied du balançoire / Swing leg	70x70x2395	2
14		Connecteur des pieds du balançoire / Swing leg connector	45x30x1730	1
15		Connecteur des pieds du balançoire / Swing leg connector	40x30x245	1
16		Élingue / Sling of swing/ rope ladder		5

