

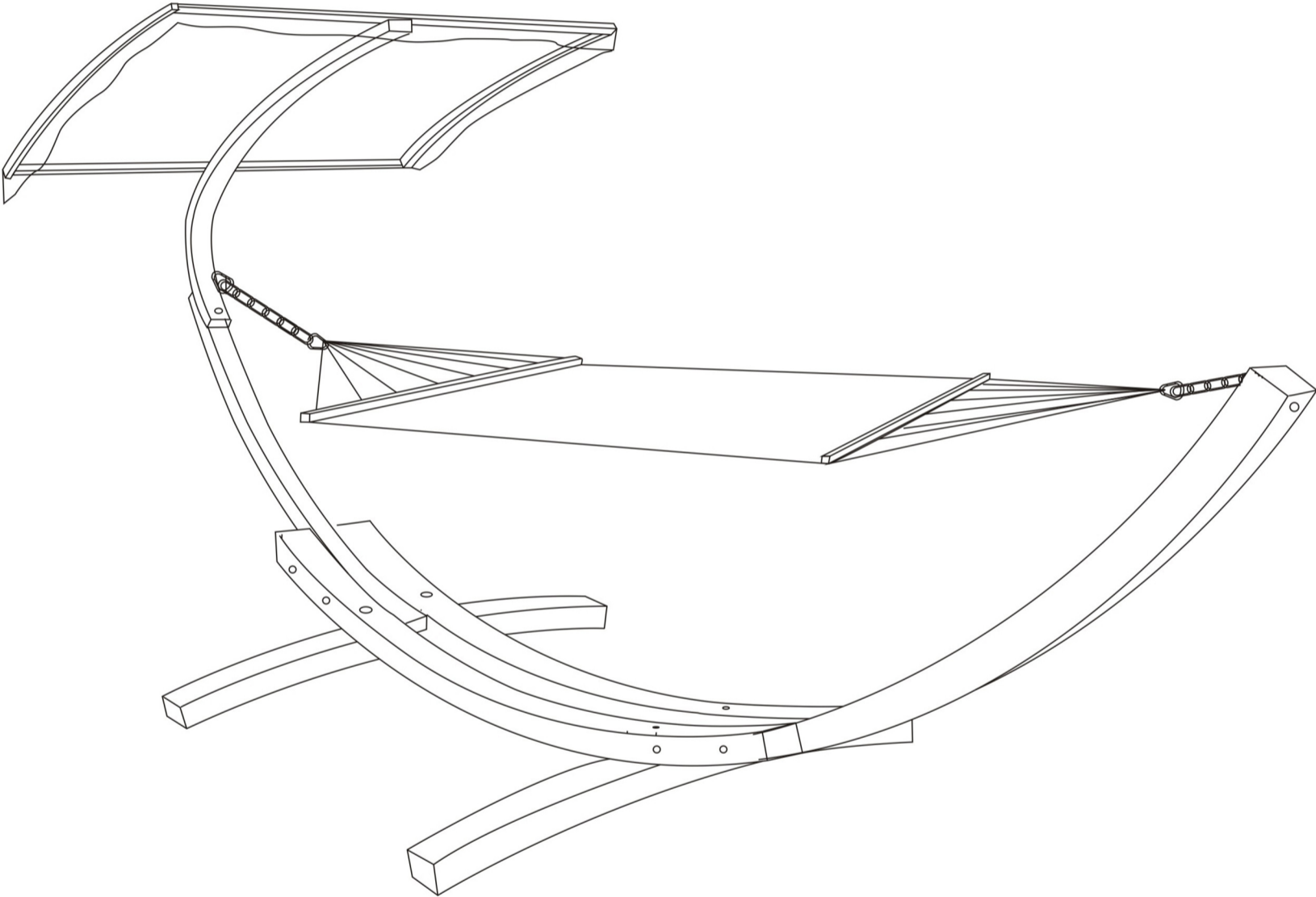













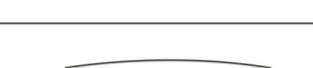



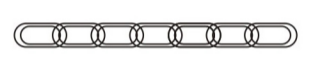

# Dallas XL

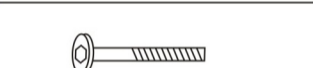
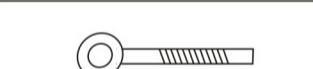
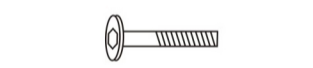
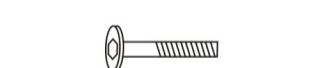
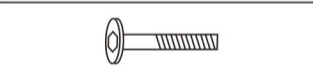
1435\_120539



PARTS	PATTERN	DESCRIPTION	SIZE	QTY
A		Hammock Support		1
A-1		Hammock Support		1
B		Wooden Beam		2
C		Feet Support		2
D		Canopy wooden bar		1
D-1		Canopy wooden bar		1
E		Canopy wooden bar		2
F		Canopy wooden bar		2
G		Washer		20
H		Hex Nut		12
J		Hook		4
K		Chains		2
L		Hammock		1
M		Pan Headed Bolt	M10*190mm	4
N		Pan Headed Bolt	M10*130mm	4
O		Pan Headed Bolt	M10*90mm	1
P		Eye Bolt	M10*90mm	1
Q		Eye Bolt	M10*60mm	1
R		Bolt	8*50mm	4
S		Bolt	8*25mm	2
T		Bolt	6*45mm	5
U		Nut		7
V		Canopy fabric		1
W		Spanner		1
X		Spanner		2
Y		Hex Socket Wrench		2

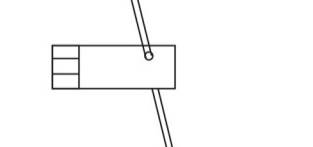
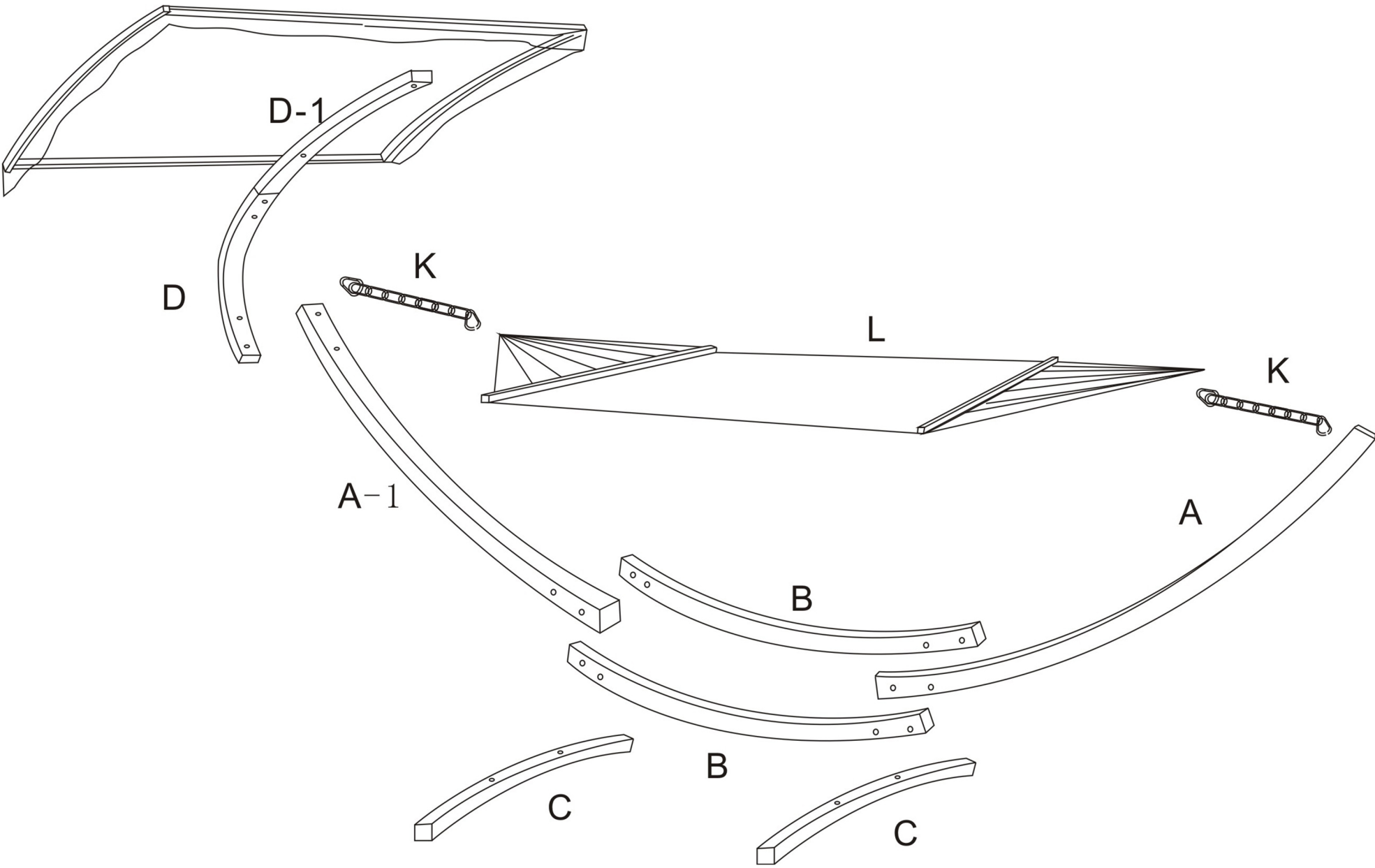

# WARNING

## EN:

1. Maintain the wood frame with wax oil every two weeks.
2. Keep the frame away from long time direct sun shine; put a cover when you don't use it.
3. Put a cover during rainy days, keep the frame surface dry.
4. Keep some distance from swimming pool to avoid direct contact with water.
5. Always wipe away the water on the frame with a dry cloth.
6. Maximum of weight capacity is 120kg. The user's weight mustn't be over this limit.

## IT:

1. Conservare le parti di legno con olio di cera ogni due settimane.
2. Tenere l'amaca lontana dal contatto diretto col sole a lungo tempo; coprire con fodera protettiva quando non viene usata.
3. Coprire l'amaca con fodera protettiva durante i giorni piovosi, posizionare il prodotto su una superficie asciutta.
4. Mantenere l'amaca a distanza dalle piscine per evitare il diretto contatto con l'acqua.
5. Asciugare bene per eliminare ogni traccia d'acqua dal prodotto con un panno asciutto.
6. La capacità massima di peso è 120kg . Il peso dell'utente non deve superare questo limite

## ES:

1. Conservar el marco de madera con aceite de cera cada dos semanas.
2. Mantenga el marco alejado del brillo directo del sol del tiempo largo; poner una portada cuando no la usa.
3. Cubrir una cubierta durante los días lluviosos, mantenga la superficie del marco seca.
4. Manténga a cierta distancia de la piscina para evitar el contacto directo con el agua.
5. Siempre limpiar el agua del bastidor con un paño seco.
6. La capacidad máxima de peso son 120kg. El peso del usuario no debe superar este límite

## DE:

1. Den Holzrahmen alle zwei Wochen mit Wachsöl aufrechterhalten.
2. Halten Sie den Rahmen vor längerer Sonneneinstrahlung fern. Benutzen Sie eine Abdeckung, wenn Sie den Rahmen nicht verwenden.
3. Benutzen Sie bei regnerischen Tagen eine Abdeckung, halten Sie die Rahmenoberfläche trocken.
4. Halten Sie Abstand zum Swimmingpool, damit direkter Kontakt mit Wasser vermieden wird.
5. Wischen Sie das Wasser auf dem Rahmen immer mit einem trockenen Tuch ab.
6. Die maximale Gewichtskapazität beträgt 120kg. Das Benutzergewicht darf diese Grenze nicht überschreiten.

## FR:

1. Maintenir le cadre en bois avec l'huile de cire toutes les deux semaines.
2. Garder le cadre à l'écart des rayons directs du soleil pour une longue durée; mettre une couverture quand vous ne l'utilisez pas.
3. Mettre une housse pendant les jours de pluie, garder la surface du cadre sèche.
4. Garder une certaine distance de la piscine pour éviter tout contact direct avec l'eau.
5. Essuyer toujours l'eau sur le cadre avec un chiffon sec.
6. Capacité maximale de poids sont 120kg. Le poids de l'utilisateur ne doit pas dépasser cette limite.

MAX LOADING WEIGHT : 180 KG

2021-2022

1

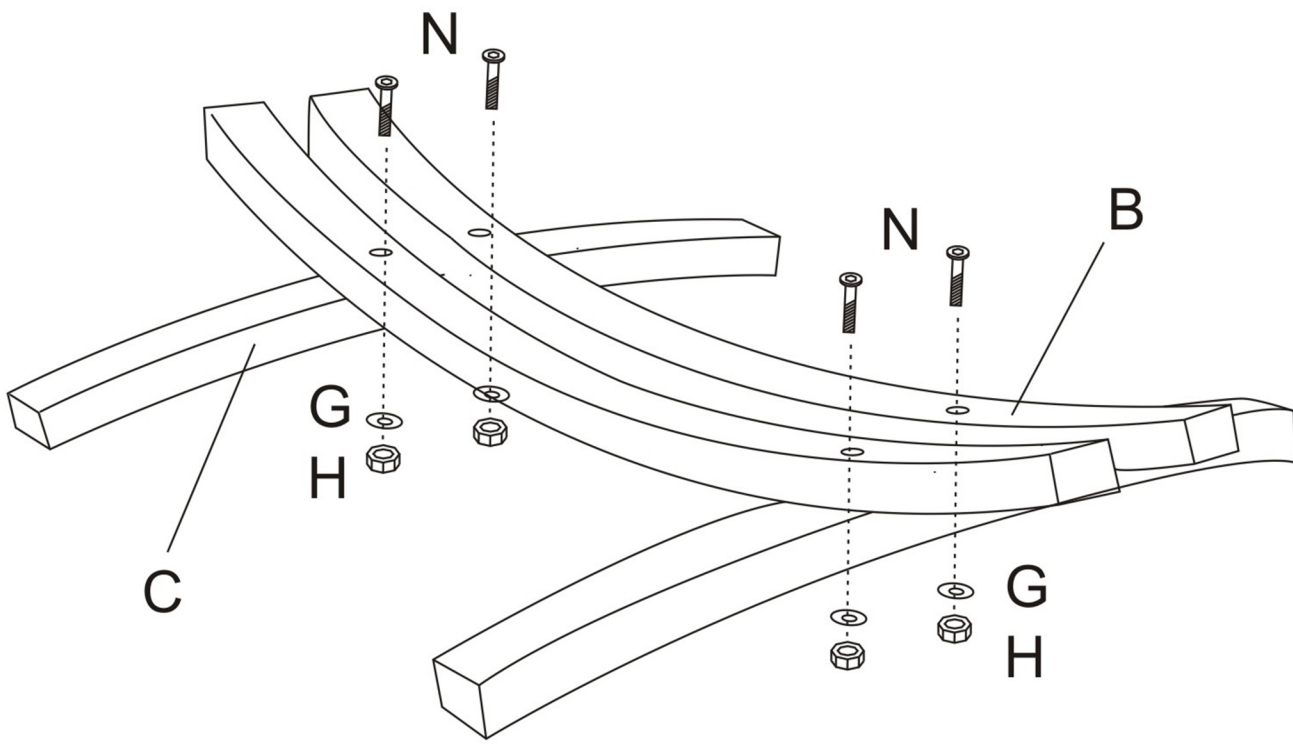

2

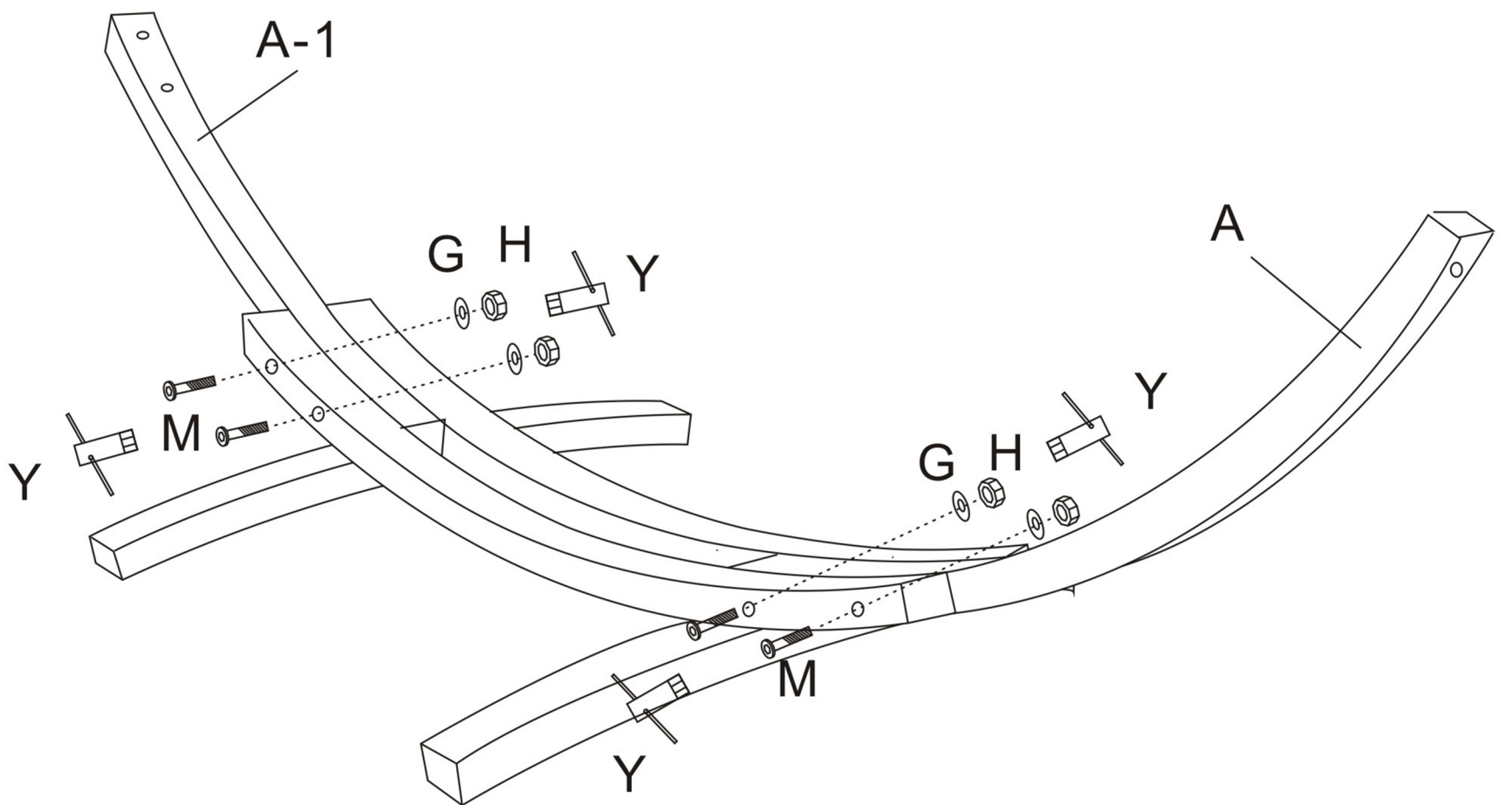

3

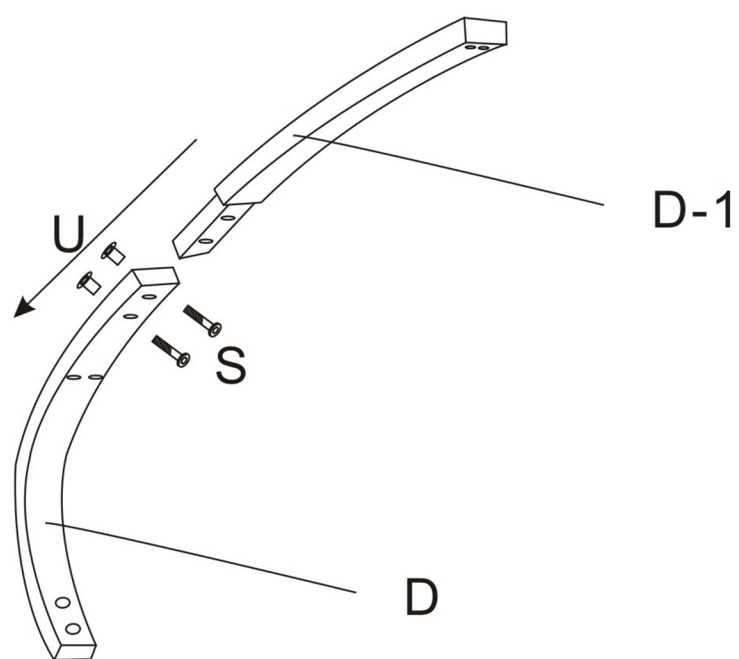
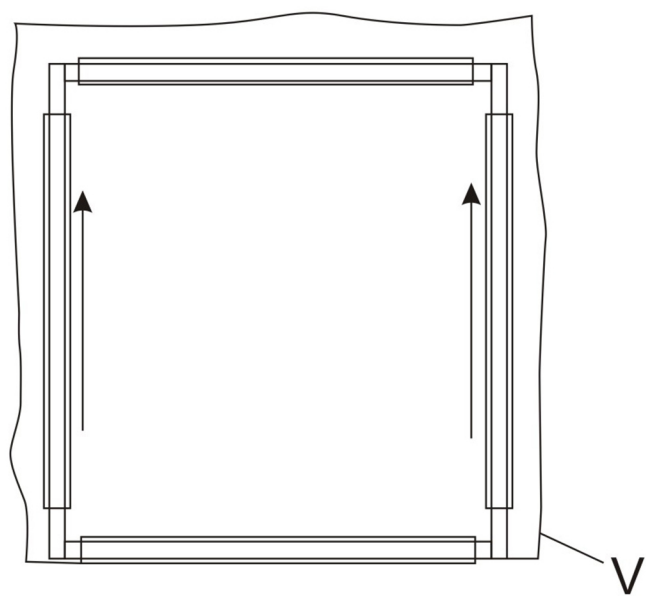

4

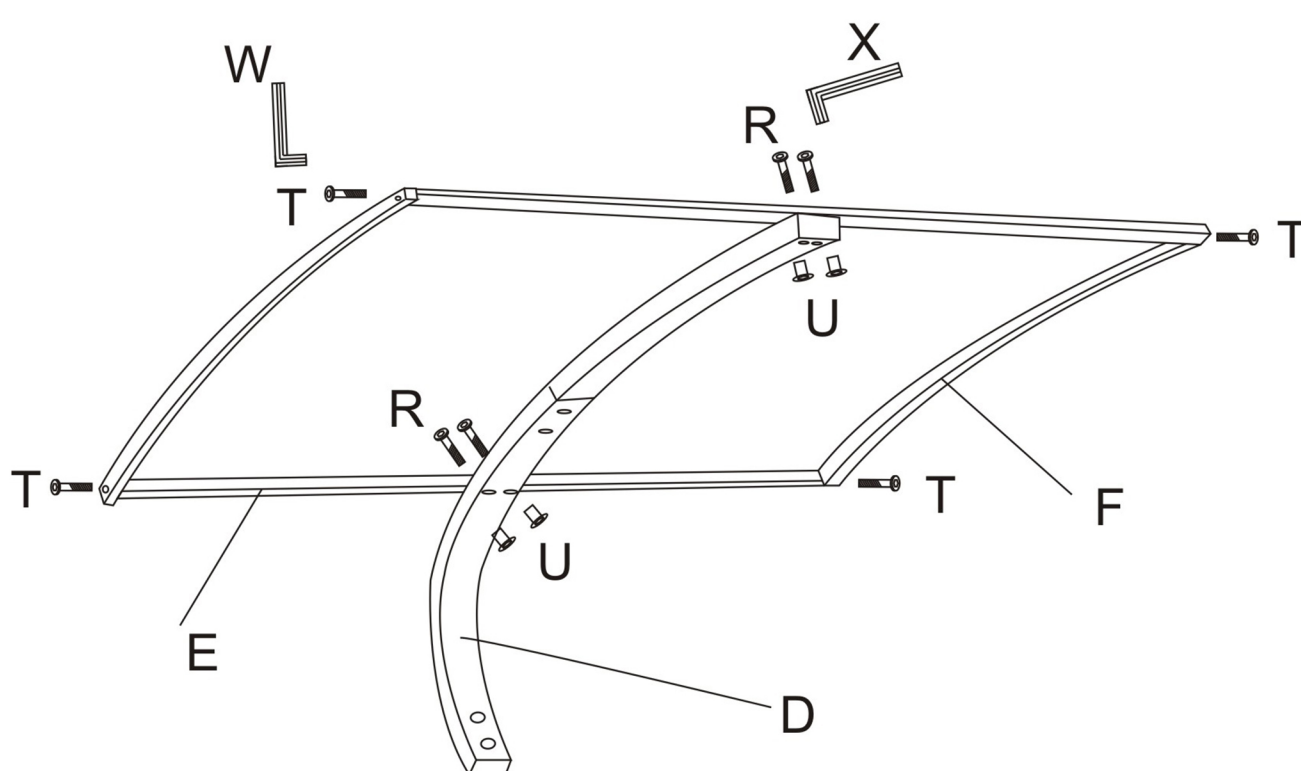

5

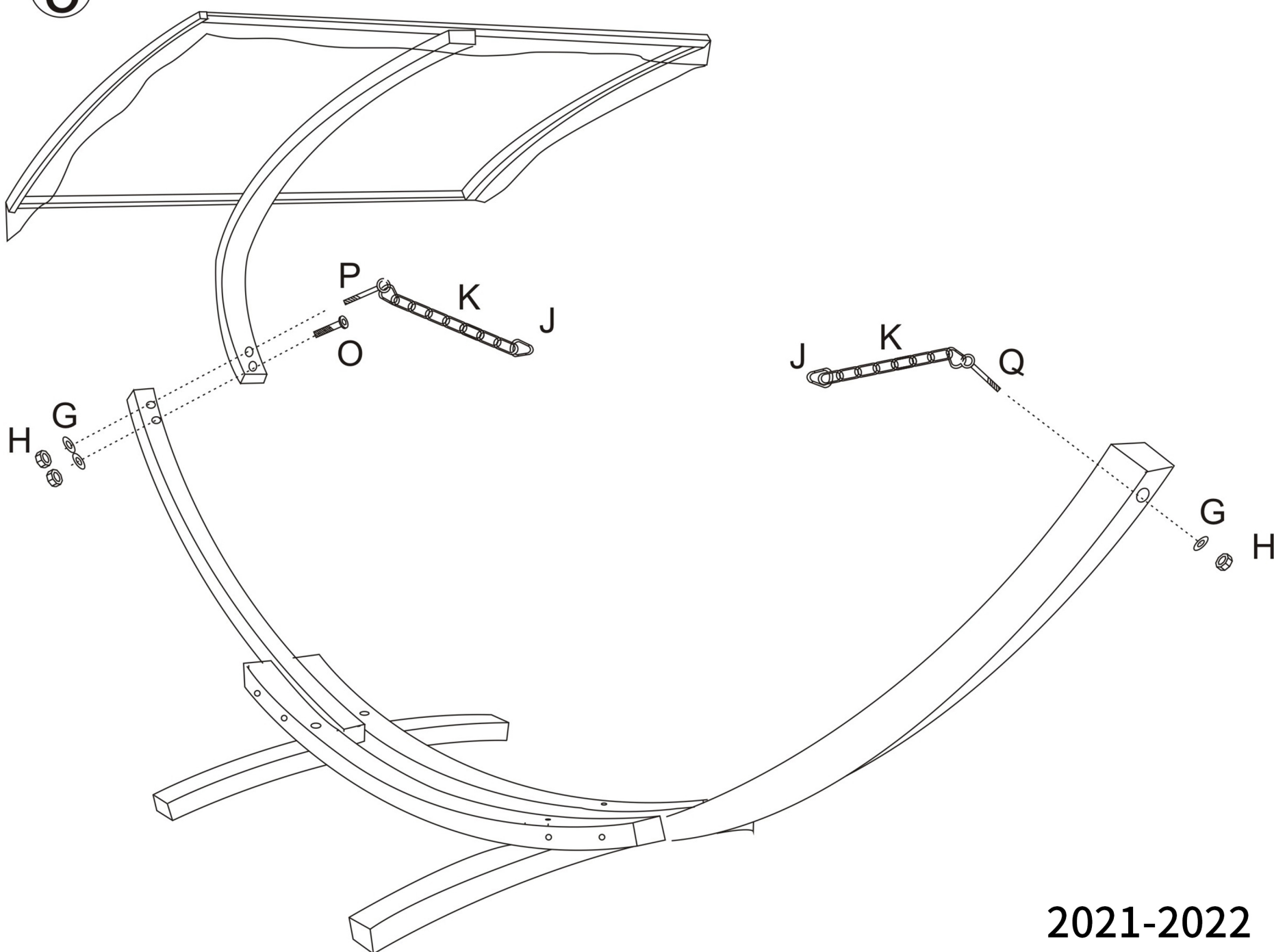

6

